

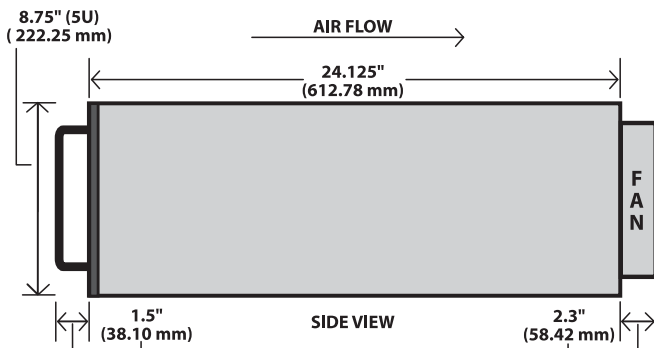

The world's leading supplier of broadband power amplifiers.

Model #: IIT500M Frequency Range: 460-510 MHz

Specifications*

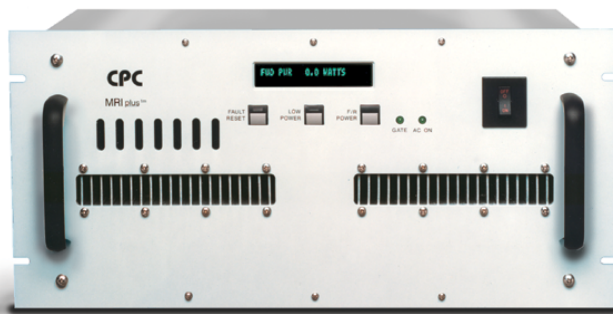

Operating frequency	460-510 MHz
Pulse power into 50 ohms	500 W (min.)
CW power	50 W (min.)
Pulse width	20-100 msec typical. 300 msec maximum, depends on output power. Consult CPC for details.
Linearity (+/- 1 dB, class AB)	500 W (min.)
Gain (0 dBm input)	+ 57 dB (nominal)
Gain flatness	+/- 2 dB, typ.
Harmonic content (2nd/3rd)	-20 dB/ -12 dBc, typ.
Input/ Output impedance	50 ohms (nominal)
Input VSWR	Less than 2:1
Duty cycle	10% (max.)
Amplitude rise/fall time	500 ns, typ.
Amplitude droop	5% to 20 ms. typ., 8% max.
Phase change / output power	12° to rated power, typ. 25° max.
Phase error overpulse	5° to 10 ms duration, typ.
Noise figure	12 dB typ.
Output noise (blanked)	20 dB over thermal, typ.
Blanking delay	1 μs, typ., on/off, TTL signal

Communication Power Corporation

80 Davids Drive, Suite 3
Hauppauge, New York 11788
Phone: 631.434.7306 Fax: 631.434.7026
email: info@cpcamps.com
Web Site: www.CPCAMPS.COM

* CPC reserves the right to change specifications without notice.



The world's leading supplier of broadband power amplifiers.

Model #: IIT500M Frequency Range: 460-510 MHz

System Features

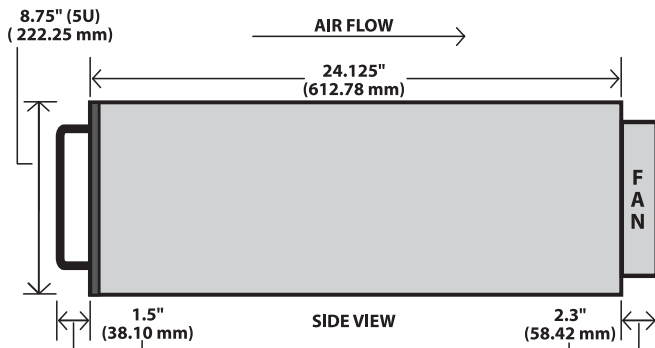
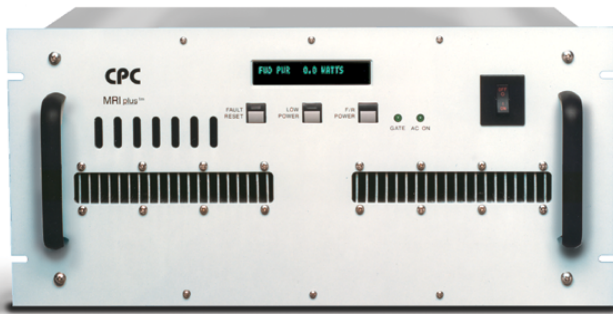

Protection functions:

- Auto/manual fault reset
- Maximum forward power
- Maximum average power
- Maximum VSWR
- Over temperature
- Power supply over voltage

Controls, front panel:

- AC power on/off
- Forward/ Reflected RF Power
- Fault reset
- Low power mode

Connectors, rear panel:

- AC mains, Receptacles, EMI filtered
- RF input: BNC (F)
- RF output: Type N (F)
- Noise blanking: BNC (F) dual polarity
- Interface: 25 pin D (F), EMI filtered
- Fwd/ Ref RF sample: SMA (F)
- Protective ground: threaded bolt

Front panel indicators:

- | | |
|--------------------|---------------------------|
| AC power on | CW mode |
| Standby mode | Power supply status |
| RF overdrive fault | Thermal fault |
| VSWR fault | Blanking (Gate) |
| Energy fault | Power limit select, Hi/Lo |

Interface functions:

- (C= Control Input F= Flag Output)
- | | |
|------------------|-------------------------------------|
| CW mode (C/F) | Standby (C/F) |
| Power supply (F) | RF overdrive (F) |
| Thermal (F) | VSWR (F) |
| Energy (F) | Power limit select Po or Po/2 (C/F) |

* CPC reserves the right to change specifications without notice.

Communication Power Corporation

80 Davids Drive, Suite 3
Hauppauge, New York 11788
Phone: 631.434.7306 Fax: 631.434.7026
email: info@cpcamps.com
Web Site: www.CPCAMPS.COM



The world's leading supplier of broadband power amplifiers.

Model #: IIT500M Frequency Range: 460-510 MHz



Environmental

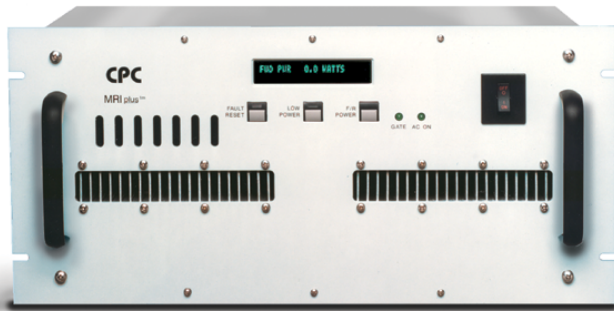

Cooling	Internal forced air, front to back flow
Operating temperature	+10 to 40°C
AC line voltage	208 VAC, +/-10%, 47-63 Hz
Chassis size	8.75 x 19 x 26 (HWD, inches) Rack mountable
Net weight	80 lbs. (approx.)
Compliance	CE, UL 2601 upon request

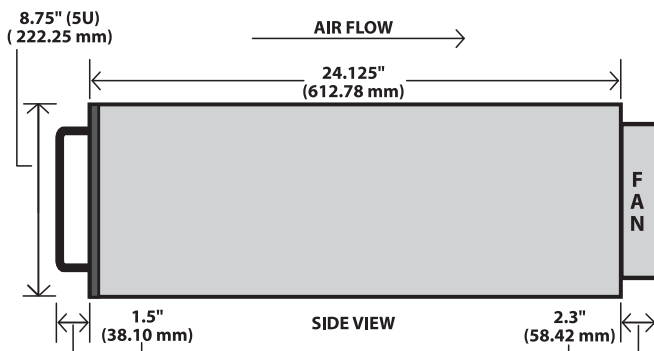

Communication Power Corporation

80 Davids Drive, Suite 3
Hauppauge, New York 11788
Phone: 631.434.7306 Fax: 631.434.7026
email: info@cpcamps.com
Web Site: www.CPCAMPS.COM

* CPC reserves the right to change specifications without notice.